

Stanley Access Technologies
Installation Instructions



Heavy Weight Door Package (Spring Open, Power Close)
with
Magic-Swing™ HDLE/FE Microprocessor Control Box
Installation Instructions

203912 Rev. A

2-8-00

Installation Instructions

TABLE OF CONTENTS

1. PURPOSE..... 1

1.1 Discussion..... 1

1.2 Applicability 1

1.3 Features and Functions 2

2. PREREQUISITES..... 2

2.1 Door Installation and Operation..... 2

3. INSTRUCTIONS..... 3

3.1 Label Application..... 3

3.2 Microprocessor Installation 3

3.3 Header Preparation..... 3

4. WIRING INSTRUCTIONS..... 4

4.1 Evaluating Power Requirements 4

4.2 Connecting Main Power Wiring 5

4.3 Wiring TB1 - Signal Inputs 5

4.4 Wiring TB2 - Sentrex³ 6

4.5 Wiring TB3 - Counter 6

4.6 Wiring Optional Power Close Module..... 7

4.7 Wiring Optional Opening Speed Control 7

5. TUNE-IN INSTRUCTIONS..... 7

5.1 Initial Tune-In Settings..... 7

5.2 Final Tune-In Adjustments 9

Attachments

Attachment 1, Magic-Swing HDLE/FE Control Heavy Weight Door Package Electrical Wiring Diagram.....10

1. PURPOSE

1.1 Discussion

This manual provides installation instructions for the Magic-Swing Spring Open, Power Close, Heavy Weight Door Package. Included are instructions for: label application, microprocessor installation, header preparation, wiring, and settings.

The Operator used in this application is configured to power the door to the closed position while compressing a coil spring. When power is removed, the force of the compression spring swings the door open. To achieve this power close, spring open functionality the operator selected is the opposite hand of the door opening hand.

1.2 Applicability

The Magic-Swing HD, Spring Open, Power Close Operator utilizes the Magic-Swing HDLE/FE control box identified by a decal with yellow text on a black background. The common name for this configuration is the black-label box. The early model control box configuration is identified by a decal with black text on a yellow background. The common name for this configuration is the yellow-label box. Black-label control boxes use a different version of microprocessor than

the yellow-label boxes. *This manual covers operation of HDLE/FE (black-label) control boxes only.* For yellow-label control box operating instructions, refer to Stanley Access Technologies document No. 203912 (11/97), "Magic-Swing™ Heavy Weight Door Package".

In addition, this operator requires a special microprocessor (P/N 713786) for reversing the Obstruction and Open/Close Logic of the Magic-Swing HDLE/FE Microprocessor Control Box.

1.3 Features and Functions

- 1.3.1 2S Logic: Switch activation commands door to open and a switch activation commands door to close.
- 1.3.2 Full Open/Part Open: The system is intended to function with two separate switches, designated "Full Open" and "Part or Half Open". Activation of the switch designated "Full Open" commands the door to cycle to the Full Open (90 degrees) position. Activation of the switch designated "Half-Open" commands the door to cycle to a reduced opening of approximately 45 degrees or ½ the spindle rotation of the operator. Either switch commands the door to close from Full Open or Half Open.
- 1.3.3 Emergency Breakout: Not available in this application.
- 1.3.4 Opening Speed. Is controlled by the Braking Resistor on the operator switch plate. An optional Speed Control (P/N 516214) is available. When optional Power Close Module is used the "Level" potentiometer controls Opening Speed.
- 1.3.5 Open Check. Is the area where the door slows before fully open and is adjusted by rotating the bottom cam on the operator.
- 1.3.6 Open Check Speed. Not adjustable.
- 1.3.7 Closing Speed. Controlled by the Open Speed potentiometer on the Control Box.
- 1.3.8 Close Check. Controlled by encoder count and switch S2 #6 on the Control Box.
- 1.3.9 Close Check Speed. Controlled by the Open Check Speed potentiometer on the Control Box.
- 1.3.10 Power Assist. The optional Power Close Module is used to power assist initial door opening. The "Level" potentiometer controls Opening Speed. The cancel feature can be wired through the Auxiliary Switch (Top Cam) to turn the power assist feature off at any given point in the open cycle. This provides for a boost to set the door in motion then let the Operator spring and controls finish opening the door. If power assist is cancelled at the full open position, no Open Check will be present.
- 1.3.11 Braking. Microprocessor software reduces the effects of door momentum near the full open and full closed positions. Open braking is applied at a selectable angle of 5 to 10 degrees. Close braking is applied at Close Check.
- 1.3.12 Torque Adjustment: Allows adjustment of the door closing force.

2. PREREQUISITES

2.1 Door Installation and Operation

- 2.1.1 The doors, even though not supplied by Stanley, must be checked for the following items as they influence the operation of the automatic door equipment:
 - Doors must swing freely on hinges or pivots of adequate size.

- Check door and frame for proper installation and clearance – 1/8” at top and lead edge, 3/16” at floor.
- If hinged, make sure hinges are firmly secure to the door and frame.

3. INSTRUCTIONS

3.1 Label Application

- 3.1.1 APPLY the orange "Important Caution" label to the back of the header or to the inside surface of the end cap for future equipment function reference.

3.2 Microprocessor Installation

WARNING

1. To prevent injury to personnel and damage to equipment, control box power must be deenergized before installing microprocessor.
2. The microprocessor box must be placed on a properly grounded anti-static work mat.
3. The service technician should be wearing a properly grounded anti-static wrist strap.

- 3.2.1 REMOVE the control box cover.
- 3.2.2 REMOVE the existing microprocessor (identified by P/N 713783) by inserting a small screwdriver under microprocessor and carefully lifting out of socket. Discard the microprocessor.
- 3.2.3 POSITION the new microprocessor (identified by P/N 713786) over the socket, so that the notch or polarity indicator located on one end of the microprocessor faces the potentiometers. Refer to Figure 1 for Polarity Indicator.
- 3.2.4 PRESS the new microprocessor carefully but firmly into the socket.

Figure 1. Polarity Indicator

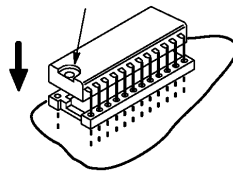

3.3 Header Preparation

- 3.3.1 PREPARE header for adequate support of operator in accordance with dimensions shown on header detail. Header must be strong enough to hold operator in use.
- 3.3.2 Refer to Figure 2 for Header Preparation.
- 3.3.3 Refer to Figure 3 for Mounting Hole Locations.

Figure 2. Header Preparation

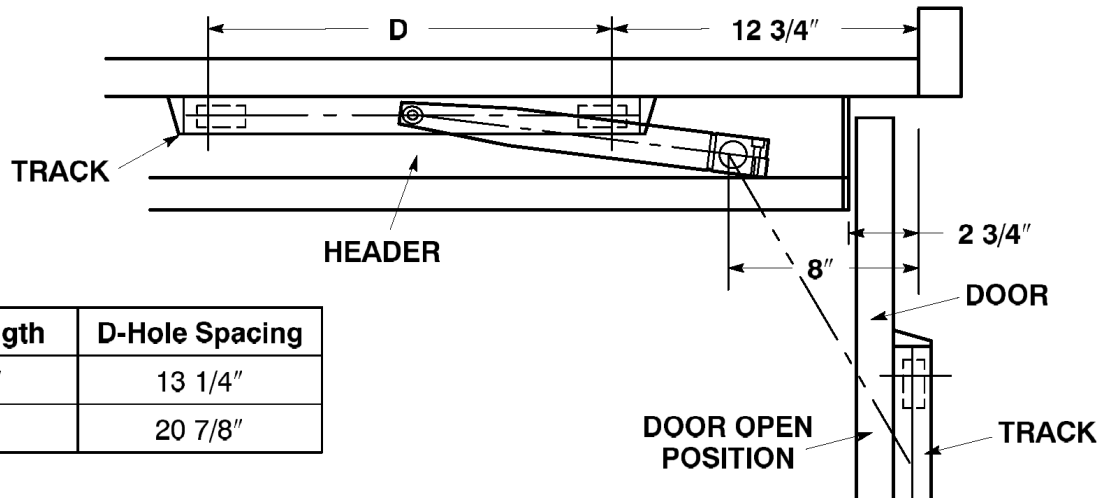

Track Length	D-Hole Spacing
15 3/8"	13 1/4"
23"	20 7/8"

Figure 3. Mounting Hole Locations

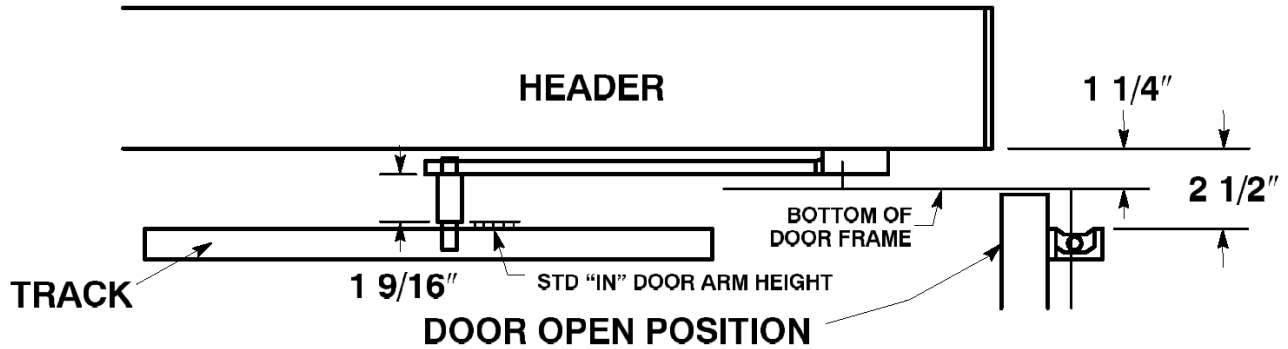

4. WIRING INSTRUCTIONS

4.1 Evaluating Power Requirements

4.1.1 EVALUATE door system power requirements as follows:

- ENSURE power source is a dedicated 117 VAC, 50/60 Hz source with 20A circuit rating per two-door system.
- ENSURE power source is not shared with other equipment, i.e., cash registers, EAS systems, or other electromagnetic interference generators.

4.2 Connecting Main Power Wiring

WARNING

To prevent injury to personnel, incoming electrical power to header must be deenergized before connecting control box electrical harness to electrical service.

- 4.2.1 DEENERGIZE incoming electrical power to header.
- 4.2.2 Refer To Attachment 1, and, using the wire nut provided, CONNECT ground wire assembly (P/N 711527) to electrical service ground wire.
- 4.2.3 In a concealed location inside the header, DRILL a hole for a No. 8 screw.
- 4.2.4 INSTALL ground wire ring terminal onto the No. 8 screw provided, and FASTEN screw and ground wire to header.
- 4.2.5 In a concealed location inside the header, DRILL a second hole for a No. 8 screw.
- 4.2.6 INSTALL main harness (J1) ring terminal onto the No. 8 screw provided, and FASTEN screw and ground wire to header.
- 4.2.7 Using the wire nuts provided, CONNECT power pigtail assembly (712846) to electrical service as follows:
 - CONNECT power pigtail assembly black wire to black (line) service wire.
 - CONNECT power pigtail assembly white wire to white (neutral) service wire.
- 4.2.8 ENSURE power pigtail assembly is *not* connected to main harness connector J1.

4.3 Wiring TB1 – Signal Inputs

NOTE

* The Control Box is shipped with a Jumper across TB1 Terminal 6 and 8. The jumper must be removed for this application.

- 4.3.1 REMOVE control box jumper from Terminal 6 and 8.

4.3.2 Refer to Attachment 1, and CONNECT the signal input wiring switch as follows:

Table 1. TB1 Terminal Wiring

TB1 Terminal	Connection
1	Signal Common
2	Full Open Press Plate Input
3	Not Used
4	12 VAC (rated at 1 amp max)
5	12 VAC
6	*Aux Input (Part Open Press Plate Input)
7	Not Used
8	*Common

4.4 **Wiring TB2 - Sentrex³**

4.4.1 Not used for this application.

4.5 **Wiring TB3 - Counter**

4.5.1 Refer To Figure 4, and CONNECT wiring for counter.

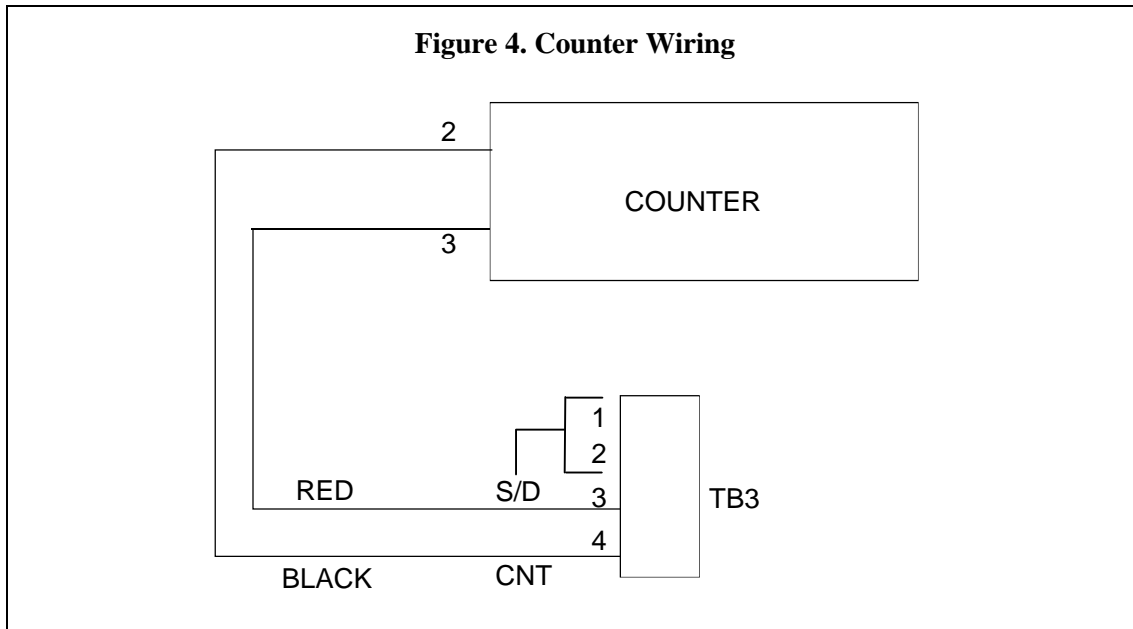

4.6 Wiring Optional Power Close Module (P/N 313367)

NOTE

The optional Power Close Module is used to power assist initial door opening. The "Level" potentiometer controls Opening Speed. The cancel feature can be wired through the Auxiliary Switch (Top Cam) to turn the power assist feature off at any given point in the open cycle.

4.6.1 Refer to Power Close Module Installation and Tune-In Manual #203863.

WARNING

To prevent injury to personnel and damage to equipment, control box power must be deenergized before connecting wiring.

4.6.2 ENSURE power pigtail assembly is disconnected.

4.6.3 Refer To Attachment 1 and CONNECT power close module wiring as follows:

Table 2. Power Close Module Wiring

Power Close Module Terminals	Connection
1	Control Box TB1 - Terminal 5
2	Control Box TB1 - Terminal 4
3	Switch Plate Wire Harness Connector - Terminal 5
4	Switch Plate Wire Harness Connector - Terminal 3

4.6.4 ADJUST the Auxiliary Switch (Top Cam) to cancel the Power Close Signal once the door starts moving.

4.6.5 ADJUST the "LEVEL" potentiometer to required door opening speed in TUNE-IN INSTRUCTIONS section.

4.7 Wiring Optional Opening Speed Control (P/N 516214)

NOTE

The Braking Resistor on the operator switch plate controls opening speed. An optional Closing Speed Control module (P/N 516214) can be wired to control Opening Speed in this application.

4.7.1 Refer to Closing Speed Control Manual for connection into system.

5. TUNE-IN INSTRUCTIONS

5.1 Initial Tune-In Settings

WARNING

To prevent injury to personnel and damage to equipment, the following settings must be made *before* applying power to control box.

5.1.1 DISCONNECT power pigtail assembly.

NOTE

1. References on printed material to “Open” or “Closed” may be reversed. Open Speed Potentiometer on control box adjusts the Closing Speed. Close Check cam in the operator adjusts the Open Check angle.
2. Adjustments to follow are for a typical installation with a door weighing 4400 to 5000 lbs. additional adjustments may be required for the installed conditions.

5.1.2 SET potentiometers and switches to initial positions as follows:

Table 3. Initial Potentiometers and Switch Positions

Control Name	Adjustment Setting
Power Close Module (Jumper Installed)	Time – Min Level – Mid Range
Closing Speed Adjustment	Min
Hold Open Delay	Not used in this application
Stall	Max
Torque	Max
Open Speed	Approx. 8 O'Clock
Open Check	Approx. 4 O'Clock

5.1.3 SET dipswitches as follows:

Table 4. Dip Switch Settings

Dip Switch	Initial Setting	Switch Function
S1	H	High / Low Range
S2		
#1	OFF	Brake Angle in opening direction: ON=5deg, OFF=10 deg.
#2	OFF	Single/ Dual Application: OFF=single, ON=dual
#3	OFF	*Brake Delay: 1 sec open, 2 sec close (see Brake Delay Table 5)
#4	ON	*Brake Delay: 1 sec open, 2 sec close (see Brake Delay Table 5)
#5	ON	First door open cycle: ON=Learn Speed, OFF=Check Speed
#6	OFF	Check Size: OFF=large check, ON=small check
#7	Not Used	

Table 5. Break Delay Switch Settings

S2-3 Position	S2-4 Position	Open Brake (seconds)	Close Brake (seconds)
OFF	OFF	0.25	1.0
ON	OFF	0.5	1.5
OFF	ON	1.0	2.0
ON	ON	1.5	2.5

5.1.4 Refer to Table 6 for 4400 to 5000 lb. door settings.

Table 6. Settings for 4400 to 5000 lb. Door

Item	Note	Setting (refer to ANSI A156.10)
OPEN SPEED	From full closed to start of open check	13.3 seconds
OPEN CHECK SPEED	From start of open check to full open	3.4 seconds
CLOSE SPEED	From full open to start of close check	12.4 seconds
CLOSE CHECK SPEED	From start of close check to full close	2.0 seconds
CLOSE CHECK CAM SETTING		10 degrees
OPEN CHECK LIMIT SWITCH (POWER ASSIST DISABLE)	Auxiliary Switch (Top Cam)	20 degrees

5.2 Final Tune-In Adjustments

- 5.2.1 ENSURE door opening path is clear of all wires and obstructions.
- 5.2.2 CONNECT power pigtail assembly.
- 5.2.3 Refer To ANSI A156.10, "American National Standard for Power Operated Doors," and DETERMINE ANSI door operating requirements.
- 5.2.4 CYCLE and RECYCLE door several times to verify proper speeds and forces.

Attachment 1.

Magic-Swing HDLE/FE Control - Heavy Weight Door Package

Electrical Wiring Diagram

